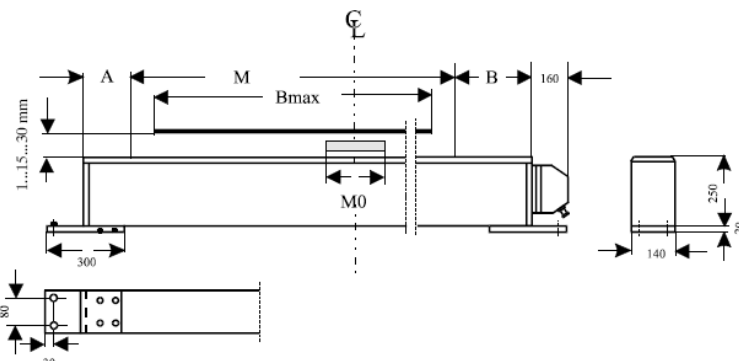

View	Application/functional description
	<p>Function: Sensing of the edge position of strip and metal foil</p> <p>Mechanical design: Extruded aluminium section with polyamide cover plate and traversing inductive edge sensors</p> <p>Hydraulic connection: Two machine plugs, screw type connection</p> <p>Colour/weight: Depending on design / length</p> <p>Application: The VKI inductive sensing system is used for sensing the strip edge or the strip centre of metal strip or foil. Both strip edge and strip centre guiding systems are possible. In the case of strip centre guiding, sensing of the strip width is possible as an optional extra. The sensing system type VKI is maintenance-free and insensitive to splash water and dirt. The sensing accuracy is ± 1.0 mm.</p>

Structure	Output of measured values
<p>The VKI sensing system consists of a measuring beam which is arranged beneath the metal strip subject to sensing, and in the immediate vicinity of a deflector roll (e. g. flatness measuring roll). The necessary electronic unit is mounted separately.</p> <p>The measuring frame is made from a rugged extruded aluminium section, the surface being covered by a glass-fibre reinforced polyamide plate to ensure splash resistance (IP67). Travelling inductive edge sensors are installed below the cover plate on one or both strip edges. They follow the strip edge in rigid position control loops and signal their position values continuously to the electronic unit. Based on these position values and the sensor covering, the positions of both strip edges, the strip position and the strip width are calculated. Data output is either via Profibus or analogue/digital signals.</p> <p>The electrical connection is carried out using two plug-in connectors which are fastened to the sides of the measuring beam.</p>	<p>Profibus L2DP – Slave Transmission format: integer in word format, beginning with data word ZERO Edge position 1; edge position 2; strip position; strip width; monitoring.</p> <p>Other interfaces are available on request.</p> <ul style="list-style-type: none"> When determining the sensing range M, a possible lateral offset of the strip must be taken into consideration. The length of the measuring beam may be selected to suit the line width, independently of the strip width. The base plates used for fastening, which are provided with 2 through-holes $\varnothing 18$ mm each, can be shifted on the lower side of the extruded aluminium profile by ± 25 mm.

Dimensions		
	<p>Measuring ranges which are not permitted:</p> <p>in the case of two strip edges, strip position, strip width</p> <p>in the case of one strip edge</p>	<p>$M_0 = 450$ mm</p> <p>$M_0 = 0$ mm</p>

Technical data											
Application:	Sensing of metal strip and foil										
Standard sensing range M:	<table border="0"> <tr> <td>only 1 strip edge</td> <td>2 strip edges/strip position/strip width</td> </tr> <tr> <td>250.... 425 mm</td> <td>500....1450 mm</td> </tr> <tr> <td>250.... 675 mm</td> <td>500....1850 mm</td> </tr> <tr> <td>250.... 875 mm</td> <td>500....2250 mm</td> </tr> <tr> <td>250....1075 mm</td> <td>500....2650 mm</td> </tr> </table>	only 1 strip edge	2 strip edges/strip position/strip width	250.... 425 mm	500....1450 mm	250.... 675 mm	500....1850 mm	250.... 875 mm	500....2250 mm	250....1075 mm	500....2650 mm
only 1 strip edge	2 strip edges/strip position/strip width										
250.... 425 mm	500....1450 mm										
250.... 675 mm	500....1850 mm										
250.... 875 mm	500....2250 mm										
250....1075 mm	500....2650 mm										
Protection type for measuring beam:	IP 67										
Sensor adjusting speed:	30 mm/s on either strip side										
Sensing accuracy:	± 1.0 mm										
(with flat guided strip)	sensing distance: 1...15...30 mm										
Temperature range for measuring beam and electronics:	0 ... + 50 °C										

Type code

VKI / 1850 / 500 / 700

	<u>VKI</u>	<u>1850</u>	<u>500</u>	<u>700</u>
assumed strip width 600. ... 1660 mm				
assumed lateral migration: ± 25 mm				
hence it follows: $M = 1660 + 50 = 1710$				
selected standard sensing range: $M = 1850$ mm				
selected dimension A = 500 mm ($A_{min} = 160$ mm)				
selected dimension B = 700 mm ($B_{min} = 410$ mm)				