

Dear customers, dear partners,

"Innovation – that is the technocratic word for the divine spark, the fire of the titans given by Prometheus to humankind," this is how it was put by Prof. Michael Stürmer once in a 2004 lecture.

Now, you can either wait for the divine spark to fall from heaven and land in the right breeding ground, or you can purposefully develop solutions to problems in innovation fields along with the future users. EMG is committed to the latter course. Developments like the electro-servo-cylinder, eMASS, inductive measurement technology for the furnace area, or the electronic wiping equipment eWIPE, are only a few examples of answers to the challenge: "problem seeks solution!"

Both now and in the future EMG does not want to leave this tested path. Our offer is available to customers and partners at any time: Are you looking for a technical solution to a demand in your production process – be it a problem related to your strip guiding system or quality assurance? Then speak with us. We will gladly discuss these topics with you on site or in our factory where we can also demonstrate prototypical solution processes.

EMG combines consulting, development, design and manufacturing along with more than 60 years of experience in the metal field all under one roof. Therefore the path from idea to solution is often shorter and more efficient than at first thought. Incidentally, the notion of "innovation" includes customer service and product-related services. This is another reason to call us.

Our associates look forward to talking with you and hearing your suggestions. Please contact Dr. Matthias Irle (matthias.irle@emg-automation.com) for topics related to quality assurance, and Thomas Dornseifer (thomas.dornseifer@emg-automation.com) for strip guiding topics.

IDEAS, INNOVATION, SPEED and PROFICIENCY – you should measure your cooperation with EMG based on these factors and take advantage of our performance. By the way, "Questions truly cost nothing at EMG!"

Anno Jordan
Sales Director
Quality Assurance Systems

Heinz Dingerkus
Sales Director
Strip Guiding Systems

Highest quality at Rasselstein with EMG-IMPOCpro

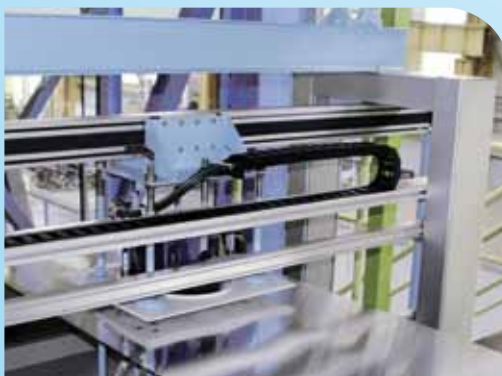

EMG, the quality assurance specialist, continually measures tensile strength and yield point with IMPOCpro at Rasselstein GmbH, the world-renowned tinplate supplier.

Rasselstein GmbH, a subsidiary of Thyssenkrupp Steel AG, is one of Europe's three largest packaging steel producers, and is Germany's sole tinplate producer. Tinplate from Rasselstein stands for quality and dependability worldwide. New materials are always being developed in order to fulfil the constant need for high-grade tinplate for new product development on the market. The key goal in mind is to develop thinner and thinner plates of consistent or even improved mechanical characteristics such as tensile strength and yield point.

Rasselstein uses IMPOCpro to determine the mechanical properties across the entire strip length continuously and promptly. It is necessary to further increase the transparency over the strip's entire length and thereby to further enhance quality, minimize risks and quickly utilize possible potential for improvement. Only in this way innovative materials can be produced at competitive prices with Rasselstein's customary high quality in the future. →

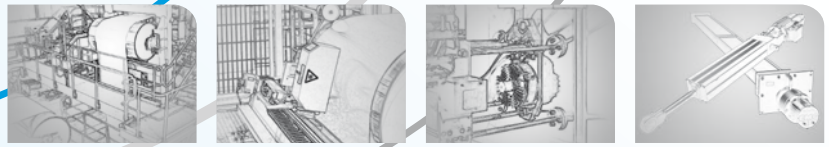

"We persuade with quality," said Alois Geyermann, plant manager at Rasselstein. "Therefore we are always willing to invest in new, promising innovations like IMPOCpro. EMG is a long-standing partner. The new IMPOCpro-measuring-system from EMG puts us in a position to raise our high standards of quality even higher. With IMPOCpro we receive even more information about our manufacturing processes. Our customers benefit from greater certainty about the quality of our materials."

At strip speeds of up to 900m/min IMPOCpro has a unique technology position on the market. For Rasselstein, this, among the measuring system's other qualities, was the decisive criterion in choosing EMG.

IMPOCpro is currently being put through its paces at Rasselstein and its peak performance is being demanded. The system is employed for all electrolytic tinning materials. The thickness of the plates ranges from 0.15 to 0.49 mm with widths up to 1,200 mm. Already today a data pool as wide as possible has been created for a flexible application of IMPOCpro at Rasselstein.

It is anticipated that the IMPOCpro-system at Rasselstein will be in regular operation throughout the course of 2009 and will significantly improve quality management. Continuous online measurement is thus an investment in the future which helps to optimize existing manufacturing processes. This guarantees the quality of even more superior grades of tinplate now and in the future.

The diverse experiences from the project will be integrated in EMG's other IMPOCpro projects. Thus the system's continued development is securely set and EMG will fulfil steadily growing customer requirements even better in the future. ■

Safety first: Protecting the plant staff and high-precision slit strip width measurement

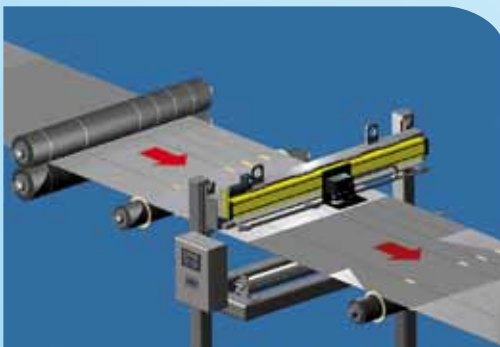

In modern slitting and cutting lines even today it is common practice to manually measure the current actual strip width of the strips after setting up the shears and slitter knives. This, however, may increase the risk of injury to operating personnel. Moreover, manual measurement of several material strips is very time-consuming.

Responding to this application case by different customers, EMG Automation GmbH has developed and successfully installed a system which automatically gauges the slit strip widths directly behind the slitting shear in a very precise manner. As a result, manually checking the dimensions of the slit strips following the set-up of the equipment is no longer necessary.

After setting up the overall system and cutting the slit strips the material feed is stopped.

By means of separating rollers or felt clamp(s) the strips are kept in their position to prevent erroneous measurements caused by loose strips or skewed strip position. While one CCD-camera is traversing above the strip, and the strip edge →

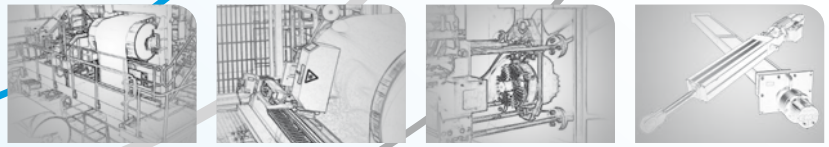

is passing along the camera's measuring range, the current actual position of the camera is determined in the vertical camera measuring axis by a highly accurate position measuring system. The 90° viewing angle towards the strip pass level helps avoid angle errors. The high resolution of the CCD-camera also makes it possible for narrow light gaps to be clearly detected between two slit strips.

The accuracy achieved with this installation is +/-0.2 mm per slit strip.

The customers' pursued project goal of "Improved safety at work in combination with high measuring accuracy of slit strips" was jointly achieved and will certainly be of interest for other companies in the field of steel processing. ■

More efficiency and process reliability in hot-dip galvanizing

The market demands perfectly galvanized sheet metal at competitive prices. Therefore it is essential that the hot-dip galvanizing process is steadily optimized and more efficiently designed. EMG uses the new generation of eWIPE electronic WIPing Equipment and eBACS electronic BAffle blade Control System in the core process of hot-dip galvanizing lines. Numerous improved details provide for an increase in process reliability through intelligent automation of the processes. Expensive downtimes due to manual intervention by the operator are avoided. Thus a higher quality of the zinc coating is reached and production errors are largely eliminated. Both systems are easily retrofitted and pay for themselves after just a short time.

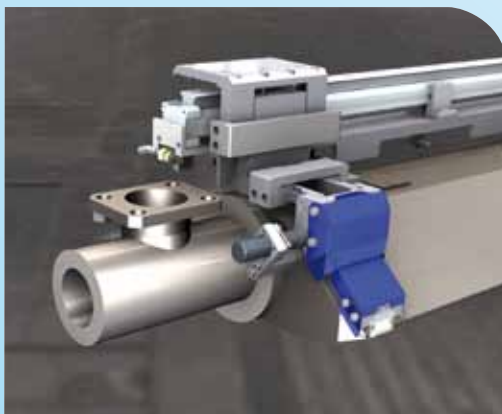

eWIPE electronic WIPing Equipment

A critical element in the galvanizing process is the lips of the air knives by which the zinc thickness on the sheet metal is set. They are positioned very close to the strip as it passes through. Contaminants on the air knife lips create air turbulence which can cause marks or streaks as well as isolated soiling of the strip. In this way the quality of the zinc coating will be compromised. Typically the air knife lips are cleaned manually, e.g. with a blade attached to a pole. This is a laborious (and dangerous to the operator) process that can also lead to scrap production or strip downtime.

eWIPE greatly simplifies and automates this process. Cleaning blades installed compactly on the air knife move within and outside the air knife and remove zinc deposits. The cleaning can be fully automated, such as at each weld, or triggered manually. The maintenance effort is noticeably reduced and the risk of accidents for operating personnel is minimized.

EMG-eWIPE cleans the air knife in the shortest time during continuous operation and thereby promotes a consistently high zinc coating quality. The system can be retrofitted to many types of air knives. →

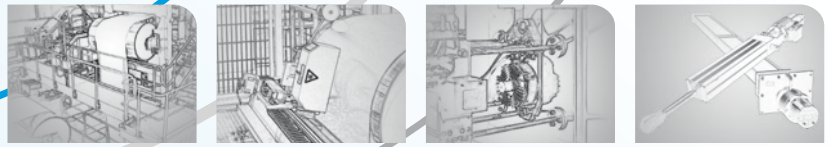

eBACS electronic BAffle blade Control System

EMG also offers another system for optimizing the manufacturing process in the area of baffle blade control with its advanced eBACS. Air turbulence caused by the air knives in the edge area creates problems in the zinc coating on the strip edge. Baffle blades optimize the air flow and provide for uniform zinc distribution especially on the strip edge. In order to prevent contact of the baffle blades with the running strip, which is also moving in its position, they are generally guided via the so-called touch rolls. These touch the strip, which can lead to flaking of the zinc coating or on thin strips even to deformation of the strip edge. EMG-eBACS is based on a magneto-inductive process and works completely without contact. For this purpose two BMI4 inductive strip edge sensors are installed on the baffle blades. The position of the strip edges are continuously identified and the baffle blades are automatically updated. The desired gap width is constantly maintained and regulated, but it can be flexibly adjusted to changing conditions.

EMG-eBACS optimizes the zinc coating on the strip edges. Contamination and damage to the zinc coating is eliminated. Sensors and actuators of proven EMG quality provide for maintenance-free, reliable operation.

With the new generation of eWIPE electronic WIPing Equipment and eBACS electronic BAffle blade Control System EMG provides its customers with solutions for higher process reliability and more quality in hot-dip galvanizing. Possible sources of errors are eliminated and thereby the production of mistakes is avoided.

Last but not least, the fully automatic systems provide for more operating safety and active protection from accidents. ■

One for All, All for One – eMASS, eSENSE, eWIPE, eBACS

Homogenous surfaces and minimal coating thickness at high production outputs are the most important thing in hot-dip galvanizing. Savings of zinc resources and perfectly consistent physical material characteristics for high quality products are the direct result. eMASS, eSENSE, eWIPE and eBACS are the EMG products that intervene in the weak spots of hot-dip galvanizing, help to optimize this highly complex process and represent a solution for the above-mentioned challenges.

EMG-eMASS electro MAgnetic Strip Stabilization is the centerpiece of the arrangements for the optimization of hot-dip galvanizing. The oscillation of the strip is typically reduced by 50% without any contact. During galvanizing the strip runs absolutely still – even at high strip speeds. Only then homogeneity and the desired specifications for zinc thickness can be precisely met. Over-coating is drastically reduced. eMASS ensures a flat, stable strip position between the air knives. The maximum crossbow is normally decreased to around +/-2 mm. →

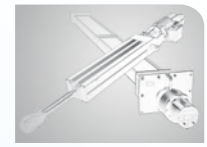
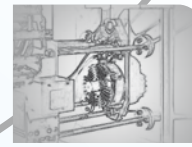

Independent of eMASS, eSENSE (electro SENSoric Strip Evaluation) gives accurate information about the actual crossbow, strip position and strip oscillation directly above the air knives. This information can be used in conjunction with the zinc coating measurement (cold measurement) for optimizing the control of the coating weights (closed loop control). In ideal cases the costly and maintenance-intensive hot measurement (of coating weight) can thereby be dispensed with. With the interaction of eSENSE, eMASS and the coating measurement an optimal running process can be guaranteed. A consistent zinc coating quality is thus achieved.

As already mentioned in the previous article, the further-developed eWIPE (electronic WIPing Equipment) and eBACS (electronic BAffle blade Control System) products keep the air knives clean during the hot-dip galvanizing process and protect the delicate strip edges from damage. In addition to quality (prevention of air knife streaks), noticeable improvements in workplace safety are also at the forefront with eWIPE.

EMG has an entire complementary system assortment at its disposal for the optimization of hot-dip galvanizing based on eMASS strip stabilization. Perfectly coordinated, the entire process is supported and secured. Each of the systems is also individually applicable for selective use. Thus EMG offers need-driven solutions for modern hot-dip galvanizing in order to allow you to produce an even higher quality final product. ■

Contact

If you have any further questions, please do not hesitate to contact:

Anno Jordan

Sales Director Quality Assurance Systems

Phone: +49-2762-612-450, Fax: +49-2762-612-384

sales@emg-automation.com, www.emg-automation.com

If you would like to stop receiving our Newsletter, please click [here](#) and write us an e-mail to opt-out.

